

YC85-8

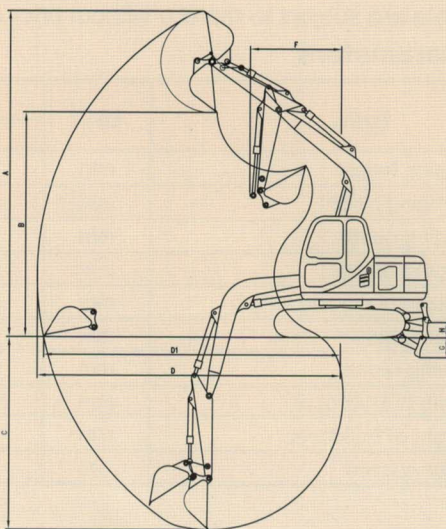

◎ Classic model of Yuchai brand. Equipped with Kubota engine. Strong power and high efficiency.

◎ Electronic-controlled hydraulic pumps. Efficient, energy-saving and easy to maintain.

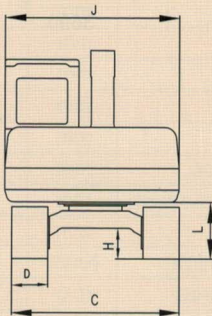
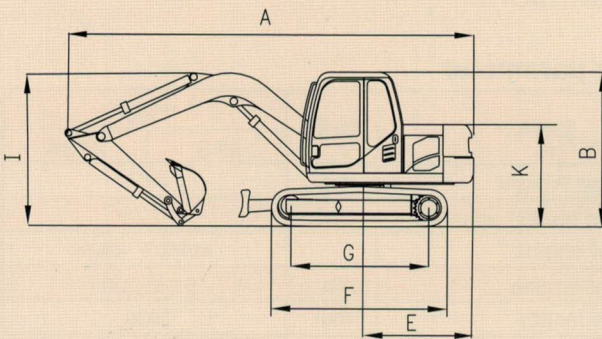

1.Dimension parameter

Code	Item	Unit	YC85-8
			860L
	Operating Weight	Kg	8100
	Standard bucket capacity	m ³	0.32
	Name of engine		KUBOTAV3800DI-E3B
	Power of engine	KW/rpm	60/2200
A	Machine length	mm	6425
B	Machine height	mm	2610
C	Overall width	mm	2185
D	Crawler width	mm	450
E	Platform slewing radius	mm	1865
F	Crawler length	mm	2784
G	Wheel-base	mm	2200
H	Min ground clearance	mm	380
I	Overall height	mm	2482
K	Height of engine hood	mm	1754
L	Height from floor to platform	mm	815
J	Width of platform	mm	2090
	Width of Bucket	mm	860
	Walking speed(low/high)	Km/h	2.6/4.5
	Platform slewing speed	rpm	12
	Cab		●
	Canopy		

Note:Technical data are subject to replace without prior notice!

2.Operating parameters

Code	Item	Unit	YC85-8
			860L
A	Max. digging height	mm	6965
B	Max. Dumping height	mm	5135
C	Max. digging depth	mm	4125
D	Max. digging radius	mm	6595
D1	Max. horizontal digging length	mm	6463
E	Max. digging height radius	mm	3298
F	Min. slewing radius	mm	2140
G	Max. depth of Bulldozer	mm	420
H	Max. height of Bulldozer	mm	320
	Max. digging force	kN	60